

MESSAGE #66: HERE IT IS...
(SPACEBAR QUILTS MESSAGE)

MSG LEFT BY: ALUMINUM GERBIL
DATE POSTED:

WELL, WHAT YE OLDE FUCK. HERE ARE THE SCHEMATICS. I DON'T THINK YOU CAN GET BUSTED JUST FOR KNOWING HOW TO MAKE COMPARATERS, SO I WILL JUST SAY NOT TO USE THEM ON ANYBODY ELSE'S PHONE. IF YOU DO, I'M NOT RESPONSIBLE FOR WHAT GOES DOWN. I REALLY DON'T CARE BUT THAT'S HOW IT GOES...
NEXT MESSAGE...

(1-70, LAST=66, QUIT=Q) READ MSG.#

MESSAGE #67: SCHEMATICS...
(SPACEBAR QUILTS MESSAGE)

MSG LEFT BY: ALUMINUM GERBIL
DATE POSTED:

OK... NOW THAT THINGS ARE COOL, I WILL GIVE YOU THE SCHEMATICS...
BUT FIRST... AS EVERYONE KNOWS, TEXT-SCHEMATICS SUCK SHIT. THAT BEITH WHY I HAVE DEEMED IT NECESSARY FOR SOMEONE TO CREATE A STANDARD ELECTRONIC CHARACTER SET. MAYBE I'LL WORK ON IT BUT IF SOMEONE COMES UP WITH ONE, ALL HAIL THE MIGHTY CHARACER SET! MY IDEAS FOR ITS CONSTRUCTION ARE LIKE HAVING STANDARD CHARACERS REPRESENT ELECTRONIC SYMBOLS LIKE THIS...

'Q' = LEFT SIDE OF HORIZONTAL
RESISTOR

'E' = RIGHT SIDE OF HORIZONTAL
RESISTOR

'R' = HORIZONTAL CONNECTION
 'T' = VERTICAL CONNECTION
 'Y' = HORIZONTAL CAPACITOR, NO

N-POLARIZED

ETC, ETC, ETC...

ANYWAY, TIS BUT A THOUGHT. IT COULD BE DONE USING HRCG WITH DOS TOOLKIT AS EVERYBODY HAS THAT, OR WHATEVER, BUT THE THING IS TO KEEP IT STANDARD FOR EVERYBODY! IF THIS CATCHES ON, MAYBE PEOPLE WILL PASSES DIGITAL DESIGN SPECS OVER THE MODULATOR...

SO, HERE BIETH THE CIRCUIT... AS SOMEONE ONCE SAID,

"FORMATTED FOR 80 COLUMNS... USE YOUR DAMN PRINTER!"...

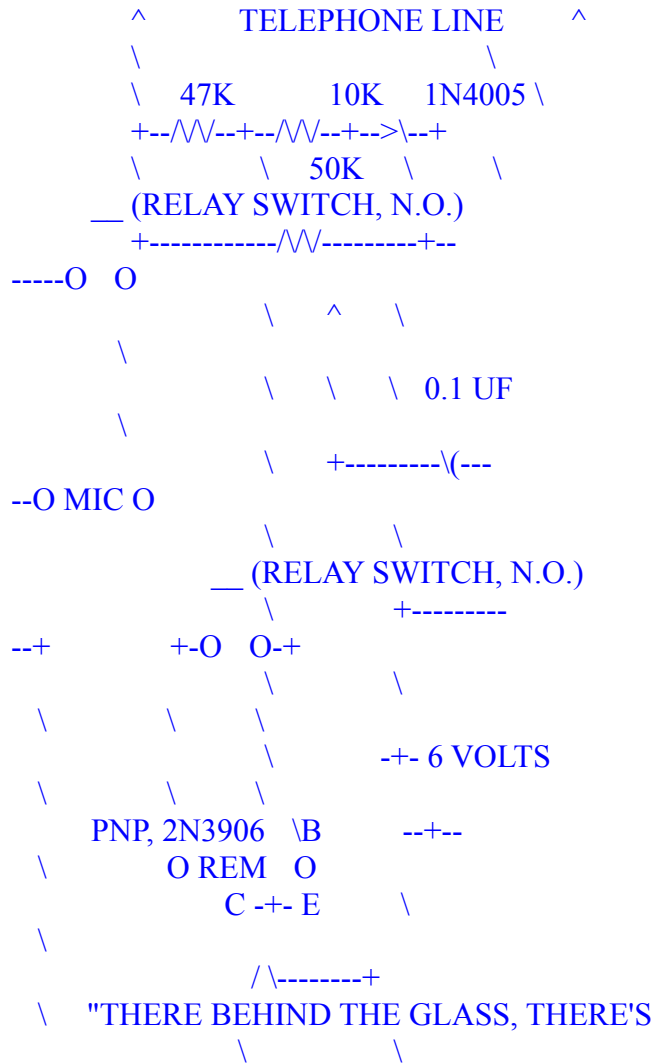

```

\  A REAL BLADE OF GRASS!  BE
      \          \
\  CAREFUL AS YOU PASS, MOVE
      \  ALONG, MOVE ALONG..."
      \          \
\    E, L & P.
      /          \
\
\  NPN, 2N3904  \B          \
\
      E +- C          \
\
      /\-----+
\
      \
\  (CONTINUED IN NEXT BULLETIN...)
      \  RELAY COIL
\
      +----!!!!!!-----
--+
```

(1-70, LAST=67, QUIT=Q) READ MSG.#

MESSAGE #68: CONTINUED...
(SPACEBAR QUILTS MESSAGE)

MSG LEFT BY: ALUMINUM GERBIL
DATE POSTED:

YEAH, SO THE ABOVE BULLETIN WAS THE SCHEMATIC. NOW FOR AN EXPLANATION. AS THE THEORY OF THIS THING WAS MENTIONED IN A PREVIOUS BULLETIN, I WON'T CONCERN MYSELF WITH THAT. FIRST A PARTS LIST...

RESISTORS... 47K OHM, 10K OHM, 1K OHM.

POTENTIOMETERS... 50K OHM TRIM POT

CAPACITORS... 0.1 UF

SEMICONDUCTORS... PNP - 2N3906 TRANSISTOR,
NPN - 2N3904 TRANSISTOR,
1N4005 DIODE.

BATTERY... ONE 6 VOLT OR FOUR 1.5 VOLT, A SWITCH WOULD BE NICE...

RELAY... I'M USING A LITTLE B

LUE 4.5 VOLT (I THINK) RELAY WITH
DOUBLE POLE, DOUBLE
THROW CONTACTS. IT'S IN A DIP
ARRANGEMENT AND I CA
N'T REMEMBER THE RADIO SHACK NUMBER...
MISC... VARIOUS SIZES OF JAC
KS FOR INTERFACING THE TAPE RECORDER,
BATTERY, TELEPHONE L
INE, ETC.

I BUILT THIS THING FOUR TIMES ON A BR
EAD BOARD AND TWICE ON A PC BOARD
BEFORE I GOT IT TO WORK TO MY SATISFACT
ION. I SUGGEST YOU BUILD IT
** BE ON A BREAD BOARD. LAST MINUTE
CHANGES ALWAYS KILL ME...

WELL, ASSEMBLE THE PARTS AS SHOWN IN
THE SCHEMATIC BULLETIN. A WORD ABOUT
THE CRYPTIC CODES...

--)\(-- IS A POLARIZED CAPAC
ITOR WITH THE NEGATIVE END POINTING
RIGHT...

-->\(-- IS THE DIODE WITH TH
E CATHODE POINTING RIGHT...

\B IS A TRANSISTOR WHIC
H IS SPECIFIED EITHER PNP OR NPN.
-+- ON NPN, THE ARROW ON
THE EMITOR POINTS OUT. ON PNP
C/\E IT POINTS IN. THE L
EADS ARE DESIGNATED, 'B' FOR BASE,
'E' FOR EMITOR AND '
C' FOR COLLECTOR

2N3904 AND 2N3906'S ARE EASY TO COME
BY. RADIO SHACK SELLS BOXES OF 15 FOR
UNDER 5 BUCKS. THEY'RE FUN TO PLAY WIT
H AS THEY ARE GOOD GENERAL PURPOSE
TRANSISTORS. I CAN'T GUARANTEE GOOD RES
ULTS IF YOU USE OTHER TRANSISTORS, BUT
IT WOULD PROBABLY WORK.

1N4005 IS THE DIODE AND CAN BE CHANGE
D FOR ANY DIODE THAT HAS APPROXIMATELY
THE SAME RATINGS, 100 PRV MINIMUM, 1 AM
P, ETC...

I RECOMMEND DURACEL BATTERY'S FOR THE SOLE REASON THAT THEY LAST LONGER THAN REGULAR CARBON BATTERY'S (UP TO 35% LONGER!) BUT IF YOU HAVE A 115 AC OUTLET NEARBY (YOU PROBABLY WON'T FIND ONE IN A PEDISTAL) YOU COULD USE A 6 VOLT POWER PACK.

STAY TUNED FOR HOW TO USE IT... [THE ALUMINUM GERBIL]

(SORRY ABOUT SOME FUCKED UP TEXT, BUT IT SEEMS TO BE PRETY OBVIOUS...

(1-70, LAST=68, QUIT=Q) READ MSG.#

MESSAGE #69: ANDSOONANDSOFORTH...
(SPACEBAR QUILTS MESSAGE)

MSG LEFT BY: ALUMINUM GERBIL
DATE POSTED:

HOW TO USE A
(COLOR\$) BOX...
AS UNSTUPIFYI
NGLY ITERATED BY:
THE [6
04] GERBIL
(SO TO
SPEAK...)

OK. NOW THAT YOU'VE MADE THE (COLOR\$) BOX AS MENTIONED ABOVE, YOU MAY WANT TO KNOW WHAT TO DO WITH IT. MANY GOOD PHREAKS MAY NOT WANT TO BOTHER READING THIS MESSAGE, AS THE USES ARE QUITE OBVIOUS. BUT THIS IS WHAT I THINK IT COULD BE USED FOR...

WELL, SAY YOU SUSPECT YOUR GIRLFRIEND OF CHEATING ON YOU... HMMM, THAT ACTUALLY IS QUITE A FRIVILOUS USE, BUT IT IS A POSSIBILITY...

OK. THE SCENARIO IS AS THUS: YOU'VE

BEEN DIALING NUMBERS IN YOUR LOCAL EXCHANGE AND YOU'VE FOUND A COUPLE COMPUTERS BUT YOU DON'T KNOW ANY PASSWORDS... WHAT YOU'D DO IS CALL UP CN/A AND GET THE LOCATION OF THE NUMBER YOU WANT TO CHECK OUT. THEN, YOU'D GO TO WHEREVER THE PLACE IS AND CHECK OUT WHERE THE SERVICE ENTERS THE BUILDING. NOW HERE IS WHERE THE SHEEP GET SEPARATED FROM THE GOATS OR THE PIRATES FROM THE PHREAKS, OR WHATEVER... WHAT YOU HAVE TO DO IS SOMEHOW GET AT THE TWO WIRES MAKING UP THE LINE. YOU COULD BREAK IN, OR YOU COULD STRIP THE WIRES ON THE POLE, OR IF THERE IS A PIT THERE. ANYWAY, YOU GET SOME BARE WIRE AND ATTACH THE BOX ACROSS THESE WIRES. THEN, YOU PUT YOUR TAPE IN AND PRESS PLAY & RECORD, TURN YOUR BOX ON AND FORGET ABOUT FOR A COUPLE DAYS. NOW, SEVERAL THINGS MIGHT HAPPEN IN THE NEXT FEW DAYS. ONE - SOMEONE MIGHT FIND THE BOX AND CALL THE PHONE COPS. TWO - THE DUDE MIGHT CALL OUT ON THE LINE IN WHICH CASE, THE NUMBERS WILL BE RECORDED ON THE TAPE. THREE - THE GUY MIGHT GET INCOMING CALLS WHICH WILL BE RECORDED. FOUR - THE BATTERYS MIGHT WEAR OUT. FIVE - THE WORLD MIGHT BLOW UP...

SO, YOU GET YOUR BOX BACK AND YOU SEE WHAT'S ON THE TAPE. IF IT'S A COMPUTER, THEN YOU PLAY THE TONES BACK INTO YOUR DEMODULATOR AND SEE WHAT IS GOING ON. YOU WILL GET ALL THE PASSWORDS, ACCESS PARAMETERS AND EVERYTHING THAT WENT ON THE LINE. SOUND INTERESTING? BUT YES, IT IS!

HMMM, DID I REMEMBER TO SAY WHAT THE FOUR PAIRS OF WIRES COMING OUT OF MY BOX ARE? ANYWAY, ONE IS THE BATTERY, ONE IS FOR THE LINE, WHICH YOU ARE TAPING INTO, ONE GOES TO THE MICROPHONE OF THE TAPE RECORDER AND THE LAST PAIR GOES TO THE TAPE RECORDER'S REMOTE

JACK.

WELL, THAT BEITH ABOUT ALL FOR YOUR LESSON ON HOW TO (COLOR\$) BOX YOUR WAY INTO PASSWORDS AND SUCH... IF YOU'VE GOT QUESTIONS, JUST POST THEM AND THE WORST THAT COULD HAPPEN IS THAT I WON'T BOTHER ANSWERING THEM AND YOU'LL LOOK STUPID, BUT THAT WOULDN'T BE NICE.

FEAR NOT, I SHALL NOT FORSAKE THEE!
PLEASE EXPECT MORE WONDROUS CIRCUIT DESIGNS IN THE FUTURE FOR OTHER FUNTTBYIST...

NUM GERBIL]

SORRY ABOUT THE FUCKED UP TRANSMISSION. AGAIN, 'TIS FAIRLY CLEAR. JUST POST IF YOU HAVE QUESTIONS...

[YE OLDE ALUMINUM GERBUL]

UP TRANSMISSION

N. AGAIN, 'TIS FAIRLY CLEAR